



# GORE® Series 600

## GASKET TAPE



### For glass-lined steel equipment flanges

GORE® Series 600 gasket tape is a form-in-place gasket for glass-lined equipment that guards against premature gasket failure. Unlike PTFE envelope gaskets, it will not degrade due to chemical attack, and will ensure a tight and long-lasting seal. GORE® Series 600 gasket tape is the ideal choice for sealing large diameter flanges. Made from 100% multi-directionally expanded PTFE, the entire gasket is chemically inert. As a result, the user will not experience the sealing problems associated with aggressive media or outside environment. This unique gasket tape conforms to the imperfections common in glass-lined flange surfaces, while maintaining dimensional stability for superior sealing reliability. This gasket tape can be installed easily and quickly, yielding initial savings. And since it minimizes unexpected process upsets, process productivity gains are also achieved.

#### TECHNICAL DATA

##### MATERIAL

100% expanded PTFE (ePTFE) with multidirectionally oriented fibril structure.

##### TEMPERATURE RANGE OF THE MATERIAL

-268 °C to +315 °C / -450 °F to +600 °F

##### CHEMICAL RESISTANCE

Resistant to all media (pH 0 – 14), except for molten or dissolved alkali metals and elemental fluorine particularly at high temperatures and pressures.

##### STABILITY

Not subject to ageing within the material's temperature range, UV-resistant and can be stored indefinitely. Storage of more than 12 months after delivery of the product may result in decline of adhesive strength.

##### PHYSIOLOGICAL SAFETY

Physiologically harmless within temperature range of material.

##### OPERATING RANGE

The maximum applicable pressure as well as the maximum safe operating temperature depend mainly on the equipment. Standard pressures range from full vacuum to 6 bar.

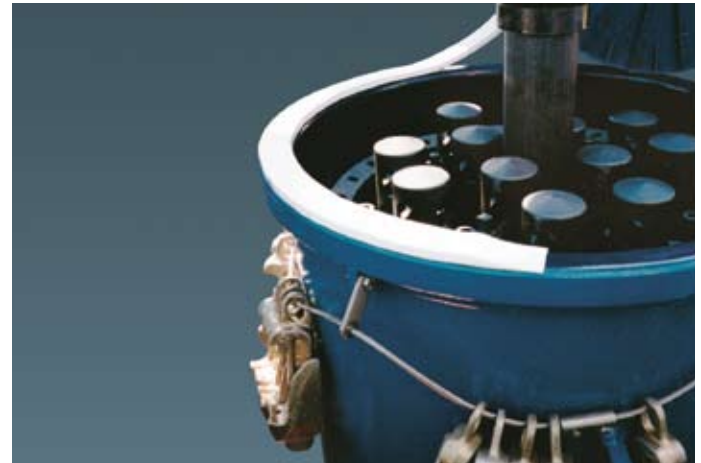

#### KEY FEATURES

- Made from 100% expanded PTFE (ePTFE)
- Resists creep and cold flow
- Wide temperature range
- Easy to install and overlay
- Dimensionally stable
- Highly conformable
- Physiologically harmless

#### KEY BENEFITS

- Superior sealing reliability in operation
- Reduces installation costs
- Can be used with virtually any media
- Retains stress for minimum retorque

#### TYPICAL APPLICATIONS

- Glass-lined mixer vessels
- Glass-lined columns
- Glass-lined storage tanks and receiver tanks





# GORE® Series 600

GASKET TAPE

## TYPICAL PROPERTIES\*\*

- AD code of practice B7

$$k_o * k_o = 24.5 * b_o$$

$$k_i = 2.5 * b_o$$

- DIN 28090

Minimum stress-to-seal

Parameters*	
DIN $\sigma_{VU}$ (40 bar, 0.01 mg (m*s))	24.5 MPa
DIN $\sigma_{VU}$ (6 bar, 0.01 mg (m*s))	20 MPa
DIN $\sigma_{BU}$	5 MPa

\*\* Above properties refer to 3 mm thickness.

Maximum stress-to-seal

$$DIN \sigma_{V0} = 150 MPa$$

- ASTM- and PVRC paramters (design codes) are available on request.

## AVAILABLE SIZE AND SIZE SELECTION

Thickness [mm]	Width [mm]		
	3	6	9
40	x	x	x
55	x	x	x
65	x	x	x

available on 2.5 and 5 m spools

available on 5, 10 and 15 m spools

The gasket width selected should be such that after installation the inside of the gasket tape ends roughly in line with the inside of the equipment. Along the outside diameter of the flange the tape should protrude at least 3 mm.

For equipment measuring up to 800 mm in diameter, we recommend 6 mm thick GORE® Series 600 gasket tape and for even larger equipment 9 mm thick gasket tape. If any irregularities are > 1 mm, the 9 mm thickness must always be used and then shimmed. In the case of irregularities over 1 mm, every additional millimetre of irregularity needs to be compensated using 3 mm thick tape.

FOR INDUSTRIAL USE ONLY. Not for use in food, drug, cosmetic or medical device manufacturing, processing, or packaging operations.

Supplied by:

## INSTALLATION

The gasket tape has an adhesive strip for easy installation.

To ensure optimum adhesion, the sealing surfaces must be totally free of grease and other residue.

The end of the gasket tape is cut using the skiving technique shown in the figure below. The tape is then fitted round the circumference of the flange. The other end is placed over the skived end and any excess cut off at an angle so that at the overlap the total thickness is approximately 120% of the original gasket thickness.

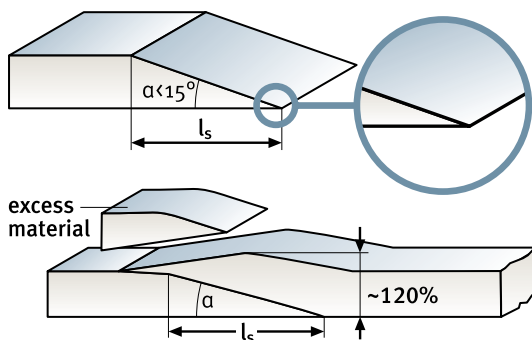

## TORQUING

The torque values recommended by the manufacturer of the glass-lined equipment must be followed at all times. It is recommended that the bolts/clamps are retorqued once after the first temperature cycle. Retorquing should only be performed after the flange has cooled down to ambient temperature.

Should you require more detailed information we would advise you to look at our separate installation instructions.

## QUALITY ASSURANCE

The GORE Quality Management System has been certified by DQS in accordance with DIN EN ISO 9001. Component suppliers are also integrated into this system.



## ORDERING TEXT

GORE® Serie 600 gasket tape, thickness (mm), width (mm), length (m)

For detailed selection criteria, technical information, installation guideline and a complete listing of local sales offices please visit [gore.co.uk/sealants](http://gore.co.uk/sealants)

**North America/South America**  
**W. L. Gore & Associates Inc. (USA)**  
 Tel.: +1 800 654-4229  
 Fax: +1 410 506-8585  
 Email: [sealants@wlgore.com](mailto:sealants@wlgore.com)

**Europe/Middle East/Russia/Africa**  
**W. L. Gore & Associates GmbH (Germany)**  
 Tel.: +49 89 4612-2215  
 Fax: +49 89 4612-43780  
 Email: [sealants\\_EU@wlgore.com](mailto:sealants_EU@wlgore.com)

**Asia/Australia**  
**W. L. Gore & Associates (China)**  
 Tel.: +86 21 6247-1999  
 Fax: +86 21 6247-9199  
 Email: [sealants\\_AP@wlgore.com](mailto:sealants_AP@wlgore.com)

All technical information and advice given here is based on our previous experiences and/or test results. We give this information to the best of our knowledge, but assume no legal responsibility. Customers are asked to check the suitability and usability in the specific application, since the performance of the product can only be judged when all necessary operating data are available. Specifications are subject to change without notice. Gore's terms and conditions of sale apply to the purchase and sale of the product.

GORE and designs are registered trademarks of W. L. Gore & Associates, © 2010-2013, W. L. Gore & Associates GmbH

